

PARÇA KODU PART CODE	PARÇA ADI PART NAME	ERKEK TERMİNAL MALE TERMINAL	a ÖLÇÜSÜ (AYAR) a MEASURE (SET)	s ÖLÇÜSÜ (KALINLIK) s MEASURE (THICKNESS)	Malzeme Material	Kaplama / Coating		
						SN	AG	Nİ
TD 2128 DP	BÜYÜK DİŞİ FİŞ TIRNAKLI 9.5 =DP=	1.20	1±0.1	-----	(CuZn30) Pirinç / Brass	-	-	-
TD 2128 DPK	BÜYÜK DİŞİ FİŞ TIRNAKLI 9.5 =DPK=	1.20	1±0.1	-----	(CuZn30) Pirinç / Brass	+	-	-
TD 2128 RP	BÜYÜK DİŞİ FİŞ TIRNAKLI 9.5 =RP=	1.20	1±0.1	-----	(CuZn30) Pirinç / Brass	-	-	-
TD 2128 RPK	BÜYÜK DİŞİ FİŞ TIRNAKLI 9.5 =RPK=	1.20	1±0.1	-----	(CuZn30) Pirinç / Brass	+	-	-

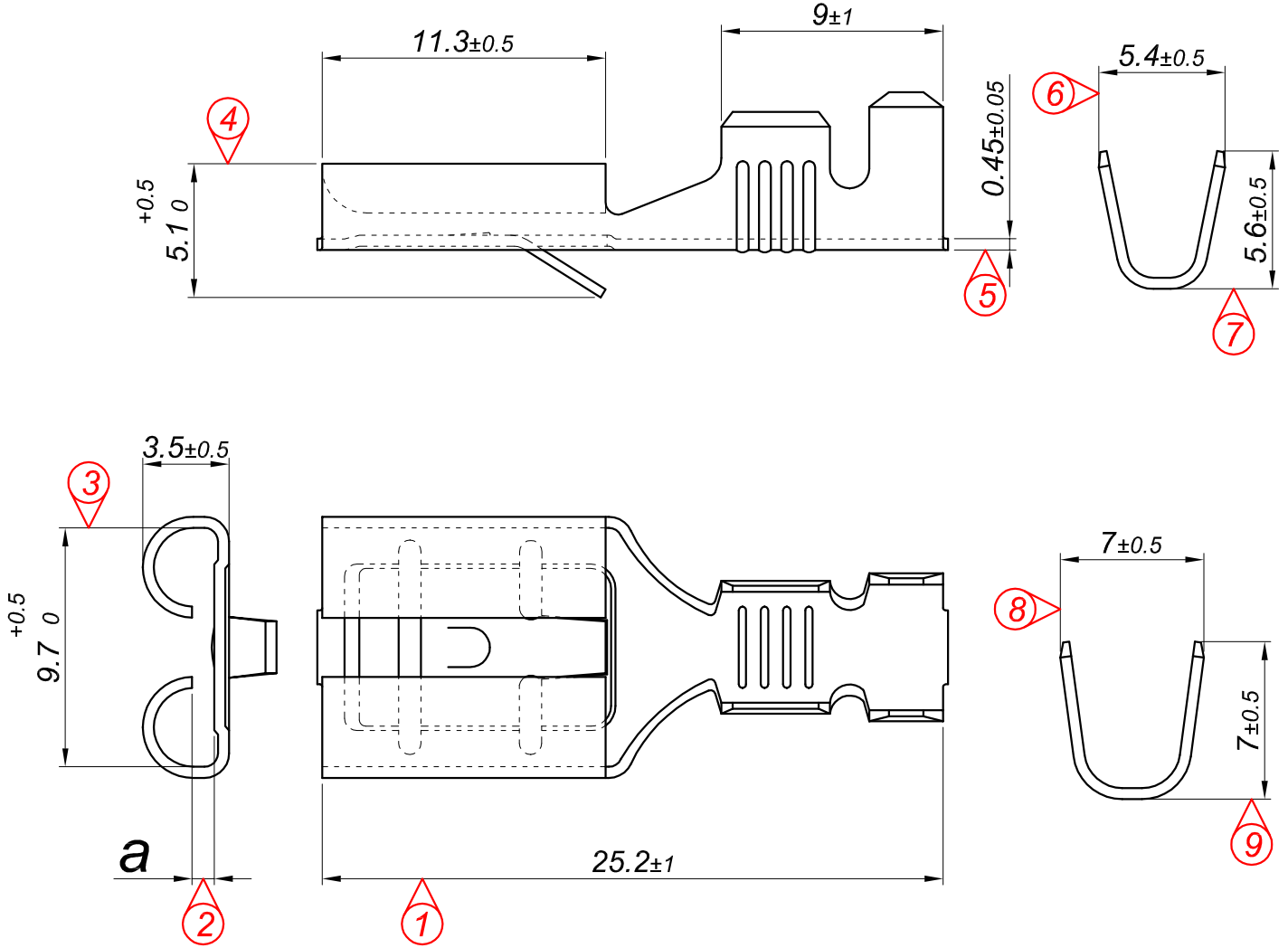

Perspektif
Perspective

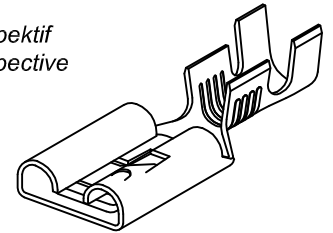

Kalıp çıkış yönü
Mold output direction

Makara açılım yönü
Reel opening direction

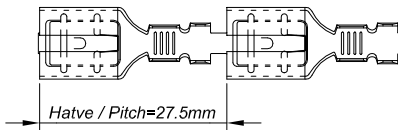

Ölçek
Scale : 1 / 1

Kablo Kesiti
Wire Section : 4 - 6 mm²

Resim üzerinden ölçü almayınız
do not measure on drawing

Tarih / Date	04.10.2011	İmza / Signature	Ölçek / Scale			
Çizen / Desing	M.Yağcı		4 / 1			
Onay / Approval	S.Gölcük		No		Değişiklik / Revision	Tarih/Date
	Parça Adı: Part Name	BÜYÜK DİŞİ FİŞ TIRNAKLI 9.5			Parça Kodu: Part Code	TD 2128